

2453-290

DATE	SYM	REVISION RECORD	AUTH.	DR.	CK.

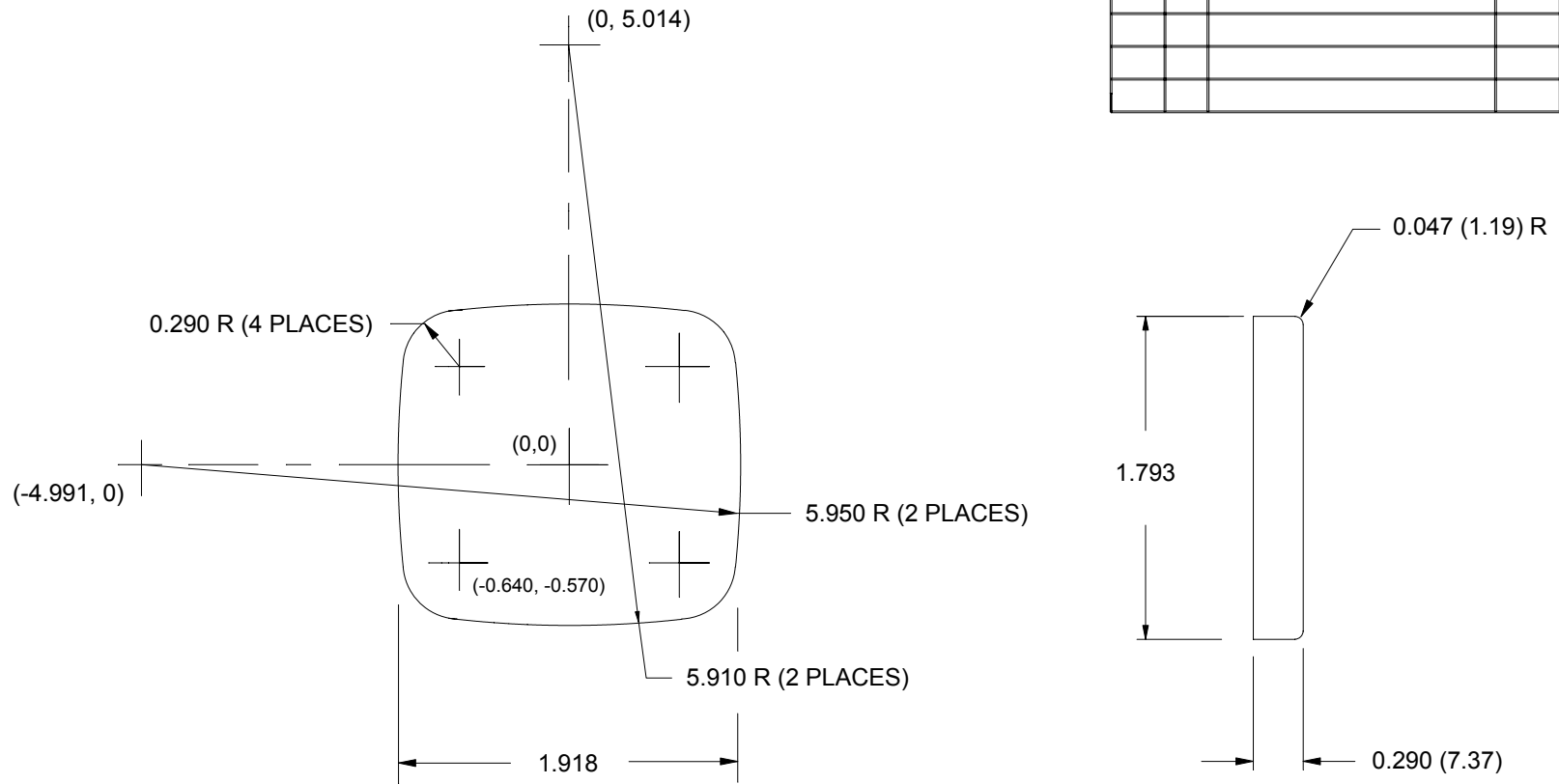

NOTE: PART IS SYMMETRICAL ABOUT HORIZONTAL AND VERTICAL CENTER LINES

TOLERANCES (EXCEPT AS NOTED)	<b>ACME METAL CAP CO., INC.</b>		
DECIMAL ± 0.005 in.	<b>MATERIAL: 0.015, 50/20 DIFFERENTIAL TINPLATE</b>	SCALE <b>1:1</b>	DRAWN BY <b>TIM DOWLING</b>
FRACTIONAL ± 0.010 in.	TITLE <b>HERMETIC COMPACT PAN - FOIL SEAL PAN DESIGN</b>		
RADII ± 1/64 in.	DATE <b>25 MAY 05</b>	DRAWING NUMBER <b>2453-290</b>	